



Standfast Corporation
Unit 2, 8 Camford Street, PO Box 1224
Milton Queensland 4064 Australia
Telephone +61 7 3369 9800
Facsimile +61 7 3369 9844
hq@standfastcorp.com
www.standfastcorp.com



Standfast International
Bischoffsheimlaan 36 - B-1000
Brussels Belgium
Telephone +32 (0)2 779 9500
or +44 (0)20 8123 1180 (UK)
hq@standfastcorp.com
www.standfastcorp.com



Standfast USA
2502 North Clark Street, Suite #207
Chicago, IL. 60614 USA
Telephone 877 850 TRAM (8726)
Facsimile 219 972 7654
tbingham@standfastusa.com
www.standfastusa.com

TOTAL RESTRAINT ACCESS MODULE OPERATOR'S MANUAL

Standard Rail-mounted TRAM System

DOC NO: TR-06-0-M-001 REVISION 1
EFFECTIVE: 4 DECEMBER 2006



CONTENTS

Introduction	1
Customer Service	1
Important Safety Information	2
Description of Equipment	4
Fall Restraint and Fall Arrest	5
Pre-Use Check	6
Operating Instructions	8
Cleaning and Preventative Maintenance	13
Periodic Examination	15
Overhaul and Repair	16
Equipment Records	16
Inspection and Maintenance Intervals	17
Equipment Record Form	19

INTRODUCTION

This Manual contains safety information and instructions for operating the TRAM system.

This Manual should be stored in an area where it is accessible to operators of the TRAM system.

Continued improvement and advancement of product design may have caused changes to your TRAM system, which are not included in this Manual.

Some photographs or illustrations in this Manual may show details or attachments that are different from your TRAM system. Whenever a question arises regarding your TRAM, or this Manual, please consult the Standfast website at www.standfastcorp.com for the latest available information.

Further information on operating the TRAM system is available in training material and courses. Further enquiry regarding these materials and courses should be directed to: hq@standfastcorp.com

The Equipment Record and an Operators Manual must be supplied to the end user when the TRAM, TRAM belt or TRAM Installation is sold, resold, rented, or otherwise made available for use. This is to ensure that the end user gets the necessary information for the safe use of the TRAM system.

CUSTOMER SERVICE

Please contact the authorised TRAM distributor in your area for enquiries regarding the operation, Periodic Examination, Overhaul and Repair of your TRAM system. The distributor nearest you can be found by consulting www.standfastcorp.com

IMPORTANT SAFETY INFORMATION

GENERAL



Do not operate or work on the TRAM system unless you have read and understand the instructions and warnings in this Manual. Failure to follow the instructions or heed the warnings could result in injury or death. Improper operation, maintenance or repair of this product can be dangerous and could result in injury or death.

No one should make any alterations or additions to the equipment. Any repair shall only be carried out in accordance with authorized procedures.

The TRAM shall not be used outside its limitations as described in this Manual, or for any purpose other than that for which it is intended.

SAFE WORKING AT HEIGHTS



The operation and maintenance of the TRAM must comply with the safety Legislation and Regulations of the jurisdiction in which it is used.

Operators of the TRAM system must be properly trained and competent.

Further enquiry regarding training materials and courses should be directed to: hq@standfastcorp.com

The TRAM restraint belt must only be used when the TRAM system is used as a total restraint system. The TRAM restraint belt must not be used if there is a risk of free fall.

Total restraint means that there is no risk of fall as the user is prevented from reaching a fall edge. This is achieved through combination of anchor point and lanyard length.

PRE-USE CHECK



Operators must carry out a Pre-Use check of the equipment, as per the instructions in this Manual, to ensure that it is in a serviceable condition and operates correctly before it is used.

It is essential for safety that equipment is withdrawn from use immediately should any doubt arise about its condition for safe use.

PERIODIC EXAMINATION



Periodic Examination should be carried out at intervals of six months or less.

Periodic Examinations are only to be conducted by a Competent Person for Periodic Examination and strictly in accordance with Periodic Examination procedures.

Equipment Records of Periodic Examination must be maintained and available to the operator.

INSTALLATION



Anyone installing or maintaining the TRAM system must read, understand and strictly adhere to the instructions and safety information in this manual and the TRAM System Technical Manual and the TRAM System Installation Instructions.

The installer must verify the adequacy of the anchor point either by calculation or carrying out a test in a sample of the material in compliance with the specifications of the appropriate Standards, as per the instructions in the TRAM System Installation Instructions.

SAFETY SIGNS AND LABELS



The TRAM system is permanently marked or labelled to indicate its purpose, correct use, limitations and other relevant safety information aimed at reducing the incidence or misuse or misfitting of the equipment. The labels also contain a unique serial number and the date of manufacture.

- A TRAM belt label is usually affixed to the front of the belt.
- A TRAM label is usually affixed to the lower section of the TRAM Arm.
- A TRAM Installation label is affixed at or close to the TRAM Installation.

The TRAM Installation label should be clearly visible to the user before the user is in a position where there is a risk of fall.

Make sure that you can read all safety signs. Clean or replace these if you cannot read the words or see the illustrations. When cleaning the labels use a cloth, water and soap. Do not use solvents, gasoline, etc., to clean safety signs. The use of solvents, gasoline, etc., could loosen the adhesive and cause the sign to fall off.

You must replace a safety sign or label if it is damaged, missing or cannot be read. If a label is attached to a part, and that part is replaced, make sure a new label is installed on the replaced part.

DESCRIPTION OF EQUIPMENT

THE TRAM SYSTEM

TRAM System - The TRAM System includes a TRAM unit that moves along a rail (the TRAM Installation), and a restraint harness attached by two lanyards. The TRAM provides the operator an ideal system of mobility and restraint. The user is firmly attached to the unit at all times and cannot fall.

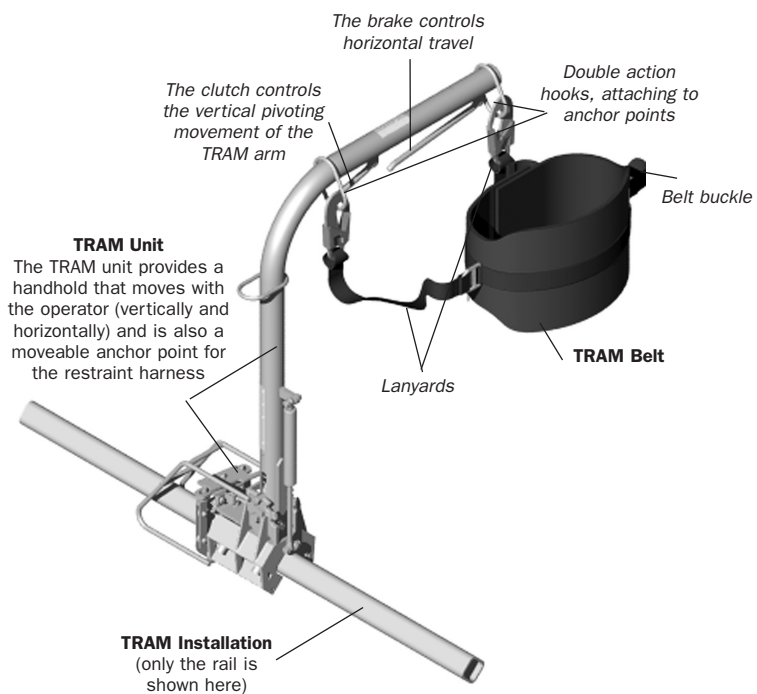

The TRAM and horizontal rail has been tested to the specifications of, and is compliant with:

EN 795:1997 Protection against falls from a height — Anchor devices — Requirements and testing.

The TRAM restraint body belt has been tested to:

EN358:2000 Personal protective equipment for work positioning and prevention of falls from a height - Belts for work positioning and restraint and work positioning lanyards.

FALL RESTRAINT AND FALL ARREST

The TRAM safety system is personal fall protection system that can be used for either fall restraint or fall arrest.

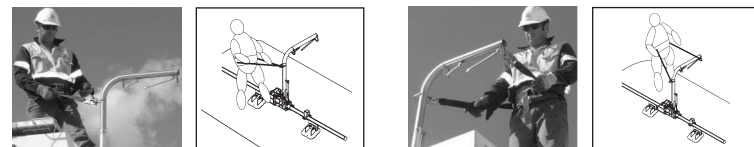

FALL RESTRAINT

It is essential for safety that if the TRAM is used as a restraint system, a fall to a lower level is not possible. The restraint belt may only be used when the TRAM is used as a restraint system. When using the TRAM as a restraint system, note that:

- The TRAM belt has two lanyards
- The TRAM arm has three anchor points

The TRAM should be used in such a way that the combination of anchor points and lanyard length does not allow the operator to reach a position where the risk of fall from height exists. The operator should normally attach both lanyards to anchor points so that it is not possible to fall to a lower level. The lanyards may be attached in any configuration and both lanyards may be attached to the same anchor point.

The operator should ensure that all work tasks can be performed without restriction

FALL ARREST

It is essential for safety that if the TRAM is used as a fall-arrest system, a full body harness and retractable fall arrester or energy absorbing lanyard must be used.

The TRAM should always be positioned, and the work carried out in such a way, that the potential for a fall to a lower level and the potential fall distance are minimized.

When the TRAM system is used as a fall-arrest system, a rescue plan must be developed prior to the system being used.

The operator should ensure that when the TRAM is used as a fall-arrest system, the distance required or necessary to arrest the fall of a worker does not exceed the potential fall distance at the work site.

If the TRAM has been used to arrest a fall it should be not used again until it is confirmed in writing by a competent person that it is acceptable to do so.

PRE-USE CHECK

Pre-Use checks are essential and should be carried out by the operator each time, before the TRAM system is used. They consist of tactile and visual inspections to ensure the TRAM system will be ready for immediate use. A visual check should be undertaken in good light.

If during pre-use checks any of the following conditions are found, immediately withdraw the TRAM belt from service and pass it to a Competent Person (see definition the next page) who will determine what action to take:

- The belt has been inspected by a Competent Person within the last 6 months
- The TRAM belt label is not present or legible
- There is any doubt about the condition of the system for safe use

TRAM BELT

Ensure that:

- There is an up-to-date Equipment Record for the TRAM belt
- There is a label on the belt, it is undamaged and can be read
- The serial number on the Equipment Record corresponds to the serial number on the belt label
- Before each use, the belt and lanyards should be checked for defects and damage have the potential to result in the failure of the belt, as follows:
 - Cuts of 1 mm or more at the edges of webbing lanyards
 - Surface abrasion across the face of the webbing, particularly if localised
 - Abrasion at the edges, particularly if localised
 - Damage to stitching (eg cuts or abrasion)
 - A knot in the lanyard
 - Chemical attack which can result in local weakening and softening – often indicated by flaking of the surface. There may also be a change to the colour of the fibres
 - Heat or friction damage indicated by fibres with a glazed appearance which may feel harder than surrounding fibres
 - UV-degradation which is difficult to identify, particularly visually, but there may be some loss of colour (if dyed) and a powdery surface
 - Contamination (eg with dirt, grit, sand etc) which may result in internal or external abrasion
 - Damaged or deformed fittings (eg connectors)

TRAM UNIT AND INSTALLATION

The Operator may need to attach to the TRAM safety system before completing all Pre-Use Checks as the TRAM and TRAM Installation are located where there is a risk of fall.

- Check the Equipment Record for the TRAM and TRAM Installation.
- Only check the TRAM and TRAM Installation labels when it is safe to do so - that is the operator may need to attach to the TRAM safety system before checking the labels, if there is a risk of fall.

The Pre-Use Check of the TRAM and TRAM installation consist of visual checks and checks of operation.

- Visually inspect the anchor points for signs of corrosion or deformation
- Attach to the lanyard hooks to the D ring anchors
- Depress the clutch lever and check that the TRAM arm is released and moves freely
- After climbing from the ladder to the elevated work area, depress the brake lever and check that the TRAM moves freely along the rail
- Check the rail for damage, corrosion or deposits of foreign material that may affect the smooth operation of the TRAM.

OPERATING INSTRUCTIONS

STEP 1

PRE USE CHECK - Always check the system before use. See previous page.

STEP 2

Place the TRAM restraint belt on.

With the neoprene style belt (shown here) ensure that the Velcro strips are aligned and secured.



STEP 3

Fasten the buckle.



STEP 4

Pull the belt strap tight.

Ensure that the double-action hooks are connected onto the belt in the "carry position" (as shown here) before climbing the ladder.



STEP 5

The double-action hooks are operated by first depressing the latch on the back spine of the hook and then opening the hook gate.



STEP 6

Proceed up ladder.

Three points of contact should be maintained on the ladder at all times.

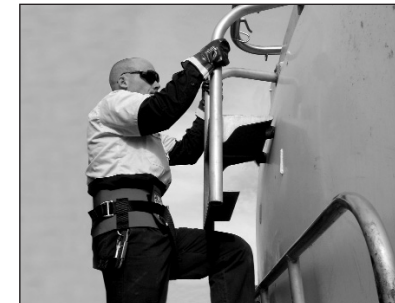

STEP 7

Stop at the lowest point on the ladder where the TRAM arm can be reached and held.

Then, maintaining three points of contact...

Unclip one hook from the 'carry position' on the belt and attach it to the anchor point on the TRAM arm. Repeat this for the other hook.

Note: Connect the right-hand hook to right-hand anchor point, and the left-hand hook to left-hand anchor point.

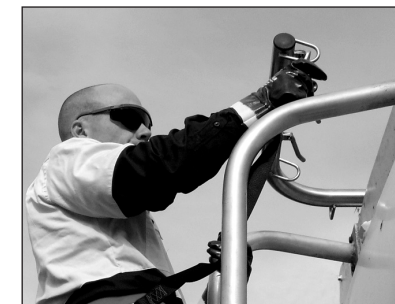

STEP 8

Hold the TRAM handhold with both hands and depress the clutch lever to allow the TRAM arm to rise.

**STEP 9**

Continue holding the TRAM handhold and depressing the clutch whilst climbing the ladder onto the platform.

**STEP 10**

Release the clutch after climbing onto the platform. The clutch system can be released to lock the TRAM arm in the vertical or 45 degree positions.

**STEP 11**

To move along the rail, depress the brake lever to release the brakes. Continue depressing the brake whilst pushing the TRAM unit along the rail.

**STEP 12**

When the desired work position is reached, release the brake.

To safely gain more freedom of movement when kneeling, squatting or sitting to work, depress the clutch and lower the TRAM arm to either the 45-degree or horizontal position. Release the clutch to lock the arm in at the desired position.

**STEP 13**

To return along the platform towards the ladder, turn and walk normally back along the walkway whilst depressing the brake handle.

**STEP 14**

The operator turns to face inwards when descending the ladder.

**STEP 15**

Three points of contact are maintained when moving from the walkway on to the ladder, because the operator grasps the TRAM with both hands through the transition.

The pivoting movement is controlled by the clutch.



STEP 16

Disconnect lanyard hooks from the TRAM and reattach to the belt in the 'carry position'

Proceed back down the ladder.

Three points of contact should be maintained on descending the ladder.

**BRAKE OVERRIDE**

If the brake system fails to release when the brake handle is depressed, the brake can be released by pressing backwards on the brake override by hand or foot.

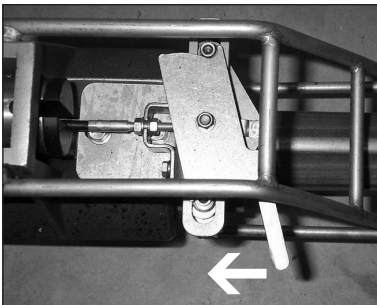
**CLEANING AND PREVENTATIVE MAINTENANCE****TRAM BELT CLEANING PROCEDURE**

1. Wipe off surface dirt with a damp cloth
2. Clean webbing and hardware with warm water and mild detergent
3. Rinse in warm water
4. Drip dry in shade

Do not place Belt near direct heat or in direct sun to dry

Do not store a wet or damp belt

TRAM DEVICE CLEANING PROCEDURE

The TRAM is constructed predominately of Stainless Steel components and is very durable in normal operating conditions.

Care should be taken not to contaminate parts of the TRAM device by allowing it to come into contact with mild or carbon steel cleaning implements.

NEVER use steel wool (wire wool) or steel wire brushes to clean stainless steel. They are usually made of carbon steel and any fragments left behind will rust onto the stainless steel surface. Using any kind of scourer which has previously been used on mild or carbon steel should also be avoided for the same reason.

1. Remove TRAM dust cover (if fitted) and visually inspect the TRAM unit for evidence of contaminants e.g. dust, stones, mud, cement, grain dust etc that will foul the working parts of the TRAM.
2. Hose down the TRAM Device, Rail & Fixtures to remove any excess contaminants.
3. Visually inspect unit again and remove any further contaminates with the aid of brushes and cleaning tools. For best results, wash with mild detergent and warm water followed by rinsing with clean cold water.
4. If any stains or surface rust remains after the cleaning steps above scrubbing may be required. Use a clean nylon scourer or a cloth with chalk-based cream cleaner. Alternatively it may be necessary to use a proprietary stainless steel cleaner. These are usually based on dangerous chemicals (such as phosphoric, oxalic or sulphamic acids) and must be handled with care according to the manufacturer's directions. After cleaning it is important to neutralize any acids with a 1% ammonia or baking powder solution followed by rinsing with clean water.

Cement and mortar splashes should be washed off before they set. Mild acids such as vinegar may be used, however avoid those using chloride rich chemicals. Do not use brick cleaning liquids which contain hydrochloric acid.

TRAM INSTALLATION CLEANING PROCEDURE

The TRAM Rail must be kept free of deposits of foreign material. Deposits may interfere with the TRAM Device Wheels affecting smooth operation of the TRAM or causing damage to the Wheel System.

1. Visually inspect the TRAM Installation, including the rail and all individual fixtures for evidence of contaminants egg dust, stones, mud, cement etc.
2. Hose down the TRAM Installation to remove any excess contaminants using clean water. Alternatively use a nylon scrubbing brush and bucket of water.
3. Visually inspect the Installation again and remove any further contaminants with the aid of brushes and cleaning tools. For best results, wash with mild detergent and warm water followed by rinsing with clean cold water.
4. If, after cleaning the Rail using the above procedure, foreign deposits remain, it is important that they are removed completely. Successful removal may require the use of an abrasive cleaning method. If an abrasive cleaning method is to be used, first ensure that the abrasive cleaning method selected is compatible with the Galvanized carbon steel rail OR the stainless steel rail (depending on your installation).

Never use steel wool (wire wool) or steel wire brushes to clean stainless steel. They are usually made of carbon steel and any fragments left behind will rust onto the stainless steel surface. Using any kind of scourer which has previously been used on mild or carbon steel should also be avoided for the same reason.

PERIODIC EXAMINATION

This section provides an overview only. Full details of periodic examination and servicing requirements are contained in the Technical Manual.

The continued efficiency and durability of the TRAM system and the safety of the user depends on regular Periodic Examination.

Periodic Examination is a more formal, in-depth inspection and should be carried out on all elements of the TRAM system periodically at intervals of six months or less.

Periodic Examination is only to be conducted by a Competent Person and strictly in accordance with Periodic Examination procedures.

It is essential that the person carrying out any inspection is sufficiently independent and impartial to allow them to make objective decisions, and has appropriate and genuine authority to discard defective equipment.

Periodic Examination should be recorded in the Equipment Record.

A Competent Person for Periodic Examination is a person who is knowledgeable of the current Periodic Examination requirements, recommendations and instructions issued by Standfast applicable to the relevant component, subsystem or system.

This person should be capable of identifying and assessing the significance of defects, should initiate the corrective action to be taken and should have the necessary skills and resources to do so.

A Competent Person is defined as a person:

- who is knowledgeable of recommendations and instructions on the TRAM System issued by Standfast (including information contained in this manual)
- who is authorised* by Standfast to carry out inspection, maintenance, servicing and repair work,
- who has the necessary training, skills and tools to perform the work properly,
- who is capable of identifying existing and predictable defects and hazards in any component of the TRAM safety system and related equipment used in the work environment,
- who is authorised to take prompt corrective action to eliminate or control hazards, and has the skills and resources to do so,
- who is familiar with relevant guidelines and national and international safety regulations.

*Your Standfast TRAM Dealer is authorised to carry out all inspection, maintenance, servicing and repair work on the TRAM System. Your Standfast TRAM Dealer may also be contacted to authorise a Competent Person.

OVERHAUL AND REPAIR

Overhaul is when the major wear items on the TRAM are replaced. Note that no overhaul or repair is performed on the TRAM belt. If the belt needs more than cleaning or preventative maintenance, it should be replaced.

The intervals represent maintenance of a non-failed TRAM. In other words, the TRAM is being rebuilt with certain new parts replacing worn parts such as main bearings.

The Equipment Record lists the components inspected, rebuilt, exchanged or replaced at overhaul.

Incidental to the replacement of these relatively few parts is the complete inspection of all other parts that are visible during the Overhaul of the TRAM.

The Overhaul interval assumes that regular Periodic Examinations have been carefully followed.

Some users may obtain significantly longer or shorter life than the chart recommends between Overhauls, but if the recommended intervals are followed, Overhauls will occur before actual failure, and the total cost of operation will be minimized.

If you experience a structural failure, which necessitates a repair, or consider that your TRAM system may have been overloaded, contact Standfast for information regarding Repair.

Standfast may authorize some repairs to be conducted by a Competent Person. The repair procedure shall be strictly in accordance with the instructions provided by Standfast.

EQUIPMENT RECORDS

Documentation is a key element of a well-managed personal protective equipment program.

Equipment Records should be maintained as proof of Inspection and Maintenance of the TRAM system.

All Orders, Invoices and Receipts should be kept with the Equipment Records.

It is the responsibility of the user organization to enter onto the Equipment Record the details required. An example template is shown on page 18.

INSPECTION AND MAINTENANCE INTERVALS

Inspection and maintenance should always be performed at the designated intervals.

TYPE OF INSPECTION / MAINTENANCE

PRE USE CHECK	Should be carried out by the operator each time, before the TRAM system is used
CLEANING AND PREVENTATIVE MAINTENANCE	May be carried out at any time as required and should be carried out at regular frequent intervals as determined by operating conditions
PERIODIC EXAMINATION AND MAINTENANCE	Should be carried out by a Competent Person on all elements of the TRAM system periodically at intervals of six months or less, or more frequently if the TRAM system is operating in extreme conditions
OVERHAUL AND RECERTIFICATION	Should be carried out on all elements of the TRAM system periodically at intervals of 5 years or less, or more frequently if the TRAM is operating in extreme conditions
REPAIR	May be carried out at any time as required

The operating environment of the TRAM also governs the Inspection and Maintenance schedule.

Under extremely severe corrosive liquid or abrasive dust exposures or for operation under extremes of temperature, more frequent Inspection and Maintenance may be necessary.

Perform Inspections and Maintenance on items at multiples of the original Inspection and Maintenance Interval.

Standfast or your TRAM distributor can assist you in tailoring your Inspection and Maintenance Intervals to meet the needs of your operating environment.

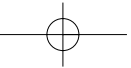

NOTES

